



Type 108

STANDARD FEATURES

- **FABRIC:** U.V. stabilised woven polypropylene
- **WATER RESISTANCE:** Lamination or polyethylene liner
- **SAFE WORKING LOAD:** Up to 1500 kgs
- **Double Point Lift**
- **Height** can be custom-made to suit your product



Quality Endorsed Company
ISO 9001 Lic 4560
Vic only SAI Global

STANDARD SIZES

BASE

- 90cm x 90cm
- 95cm x 95cm
- 100cm x 100cm

HEIGHT

- 90cm • 160cm
- 120cm • 180cm
- 140cm

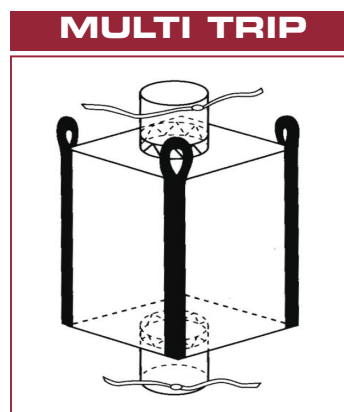
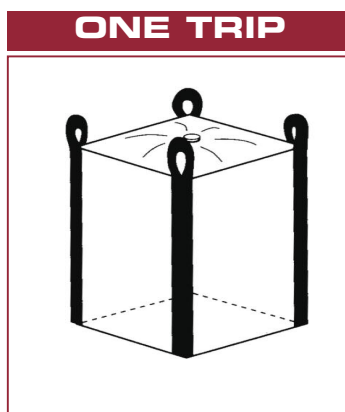

ONE TRIP

Flap/
Open Top



Closed Bottom

A

Duffel Top



Closed Bottom

B

Spout Top



Closed Bottom

C

MULTI TRIP

Flap/
Open Top



Discharge Spout

D

Duffel Top



Discharge Spout

E

Spout Top



Discharge Spout

F

Bulk Handling Australia Group Pty Ltd

VIC/TAS	45 Centre Way, Croydon South, Vic (H.O.)	+ 61 3 9761 4433
NSW	Unit 2, 105 Kurrajong Ave, Mt Druitt	+ 61 2 9625 3599
WA	Suite 9, 36 Johnson St, Guilford	+ 61 8 6278 3033
QLD	46-52 Nealdon Dve, Meadowbrook	+ 61 7 3200 8000
SA/NT	283-287 Sir Donald Bradman Dve, Brooklyn Park	+ 61 8 8238 3245
NZ	20 Northcroft St, Takapuna, Auckland (H.O.)	+ 64 9 486 0050

Customer Service Excellence Team:

custserv@bha.com.au